

THE NEXT GENERATION OF ADVANCED
FORMING TECHNOLOGY.

PRESENTING NovaMax500™

- > Excellent product quality
- > Superior productivity
- > Advanced hygiene
- > Lower cost of ownership

FORMAX®
There's more in it for you.



Servo Knock-Out Drive

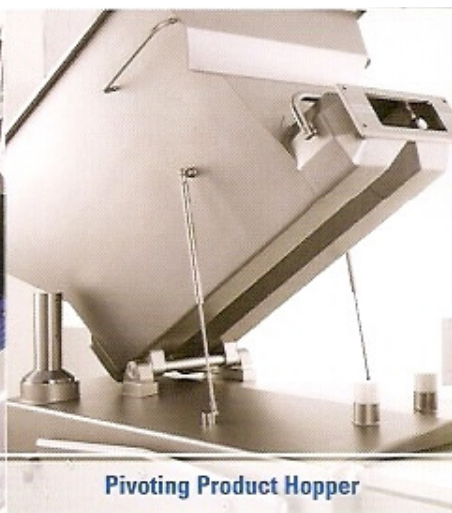

Pivoting Product Hopper



NovaMax500™ A NEW GENERATION SYSTEM PROMISING HIGHER QUALITY AND A LOWER COST OF OWNERSHIP.

- > All servo/electronic performance
- > Next generation rotary pump system
- > Hygienic one-piece pump box
- > Easy cleaning pivoting hopper
- > Advanced touch screen control
- > Utilizes existing F-19™ tooling

The NovaMax500™ forming system brings a new generation of advanced technology to the floor as only the combined power of Formax® and Provisur® Technologies can provide. Never before in our history has one forming system brought forth so many innovations and benefited our customers so greatly. In the NovaMax500™ design, we employed our every resource to push the envelope of innovation and develop a system that's clearly delivered the best possible product quality at a low cost of ownership.

Heading the list of exclusive NovaMax500™ advantages is a revolutionary rotary product pump that protects product integrity, improves filling cycle consistency and reduces leakage. An all servo/electronic design that completely eliminates hydraulics and pneumatics ensures the very lowest cost of ownership – not to mention this system's ability to utilize all existing F-19™ tooling and accessories. Hygienic features are unmatched with our advanced uni-body frame construction, a rigid one-piece pump box and a pivoting hopper that tilts for easier cleaning.

The NovaMax500™ forming system delivers tomorrow's solutions in providing our customers with all the advantages they need to compete. And it's backed by Provisur® Technologies' worldwide 24/7 technical support so there is the added assurance of owning the industry's best.

Pivoting Product Hopper and Servo Feed Screw

A pivoting product hopper delivers the higher productivity and food safety Formax® customers have come to expect. Feed screws and pump movement are controlled to reduce product overworking to optimize texture and maximize quality. The pivoting feed screw drives, hopper and removable feed screws allow for easy cleaning and reduced maintenance costs.

Touch Screen Interface

NovaMax500™ introduces a next generation 15" (381 mm) touch screen interface that's as advanced as it is easy to use. Operators can choose from a full range of operating and diagnostic screens in multiple languages and make adjustments to key parameters on the run.

Servo Knock-Out Drive

Precise product placement to downstream conveying systems is provided by programmable knock-out motion profiles powered by advanced servo drives. It optimizes performance and works in sync with conveyors on a product by product basis.

One-Piece Pump Box

When it comes to food safety and lowering ownership costs, NovaMax500™ incorporates the most advanced technologies available. Its one-piece pump box cleans easily and offers a true running surface that ensures tooling components are precisely aligned. This reduces mold plate drive loads, leakage and drives costs down.

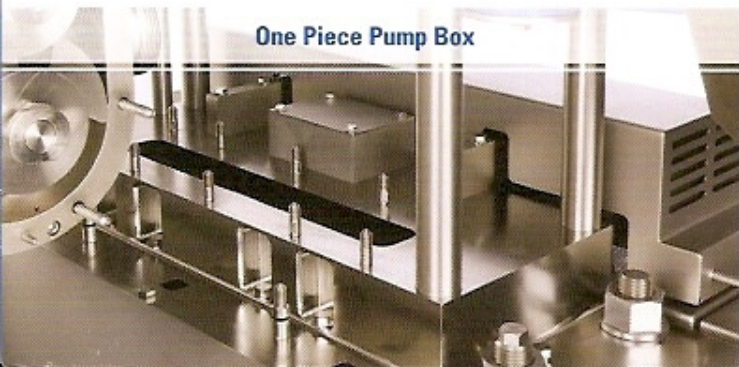

One Piece Pump Box



Servo Feed Screw

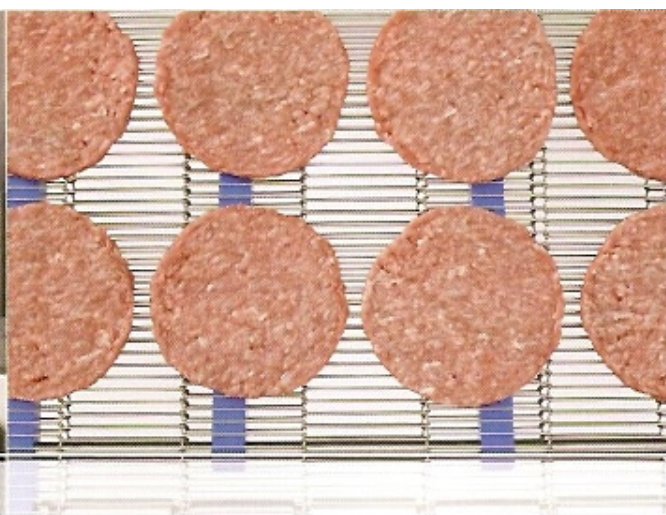

Revolutionary Technology In A Servo Controlled Rotary Product Pump

Innovative world-class technologies, like its servo controlled rotary product pump, are employed in the NovaMax500™ design to ensure excellent results. From its very first filling cycle at startup, the rotary pump works to produce a more consistent product and reduce leakage as the rotors are entirely contained. In addition to offering a lower cost of ownership, the rotary pump also enhances product texture.

Direct Drive Servo

As a next generation forming system, NovaMax500™ was designed to form a wide range of products with superior texture and product consistency. The system easily tackles speeds up to 100 strokes per minute and production rates to 6,000 pounds per hour. And its all servo/electronic construction which means there is greater operator control over the various mold plate actions, matching the unique characteristics of the product being formed.

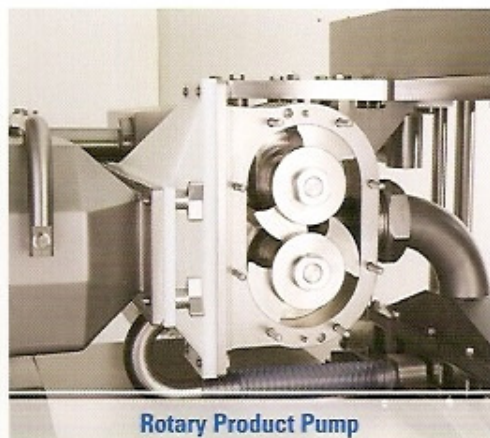

Rotary Product Pump

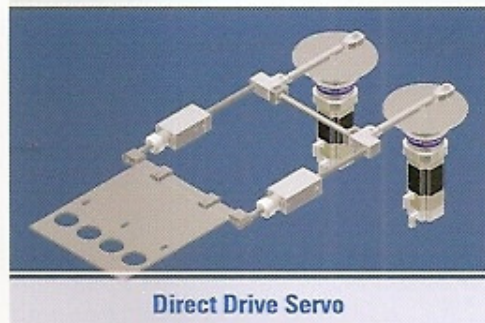

Direct Drive Servo



NovaMax500™ INSTALLATION DIMENSIONS Inches and Metric

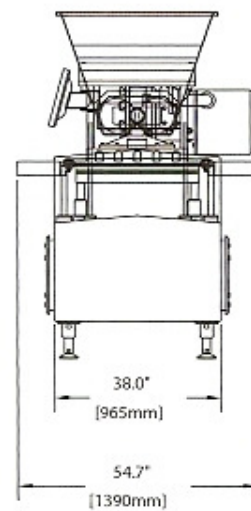
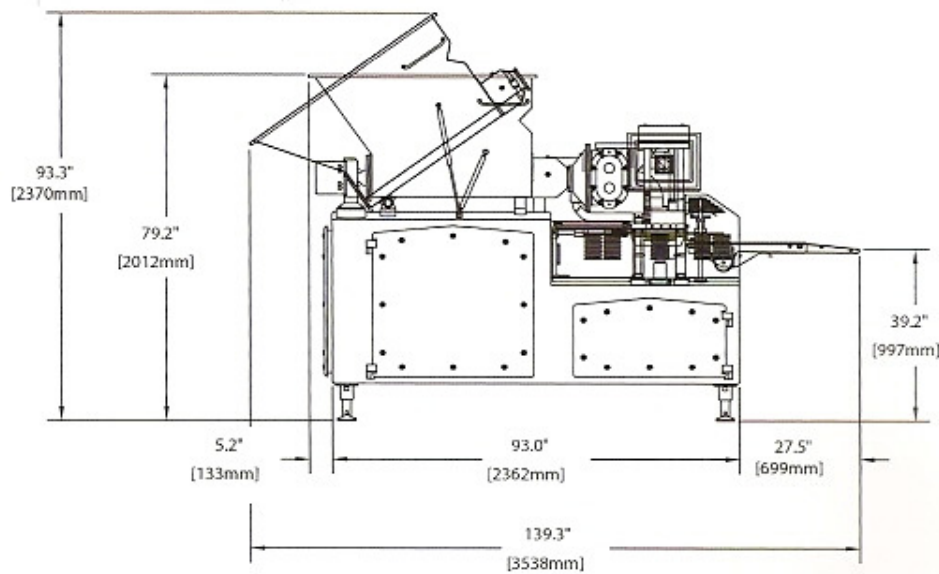
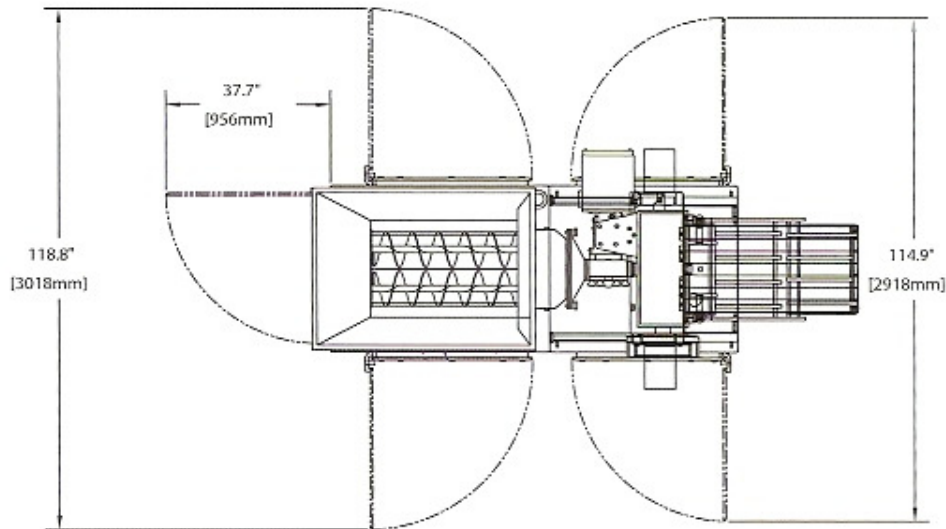

Gross Weight = 6,025 lbs (2733 kg)
Gross Weight w/Paper System = 6,525 lbs (2960 kg)

FORMAX
There's more in it for you.

NovaMax500™ FEATURES & SPECIFICATIONS Inches and Metric

FEATURE	SPECIFICATION
Product	Red Meat, Poultry, Pork, Fish, Soy, Other
Variable Mold Plate Drive	25-100 at 9" (228mm) stroke length
Strokes Per Minute (SPM)	100 SPM Max
Production	Up to 6,000 lbs (2722 kg) per hour
Touch Screen Control	Advanced 15" (380mm)
Tooling Usage	All current F-19™ tooling
Usable Mold Plate Area	19.0" (483mm)
Fill Type	Standard, Port-Fill®, Tender-Form®, Verti-Form®, Standard Configuration
Portion Shape	All 2D, 2.5D or 3D
Portion Thickness	.200" to 1.0" (5mm to 25mm)
Knockout System	Servo/Mechanical w/K.O. Cups
Mold Plate Drive	Dual Servo Crank Arm
Product Pump	Rotary – Integrated on Former
Hopper Capacity	1,000 lbs (454kg)
Pump Box	One-piece Verti-Form®, Tender-Form®, Standard Configuration
Hydraulics	None
Pneumatics	None
Product Pressure Control	75-250 PSI (5.2-17.2 Bar)
Wireless Ethernet Connection	Included
CE Compliant	Yes
UTILITIES & SAFETY	
KVA Rating (Includes optional bucket lift, knockout heater and paperfeed system)	23 KVA
Electrical Configuration	400/460 Volts, 50-60 Hz, 3-Phase 32/37 Amps
Water Requirements (Knock-out heater/atomizing water spray)	30 PSI min., 1 GPM at 50F / 30 PSI min., 2 GPM at 50F (2 Bar min., 3.8 LPM, 10C / 2 Bar min., 7.6 LPM, 10C)
Air Requirements (Non-paperfeed/paperfeed)	1 CFM at 80 PSI / 15 CFM at 80 PSI (28.3 LPM at 5.5 Bar / 424.8 LPM at 5.5 Bar)
Cross Monitoring Safety Interlock System	State of the art components
Radiant-Type Heater for Knock Out Cups with Adjustable Temperature Control and/or Water Spray	Available by application
PAPER FEED SYSTEM (Optional)	
Mountable servo driven or Stand-alone	Per Specification
Strokes Per Minute	100 SPM at 9" (229mm) stroke length
Paper Interchangeability	Paper hopper, vacuum bar and vacuum cups are easily removed to change sizes
Standard Paper Sizes (consult factory for custom paper sizes)	4.25, 4.5, 4.75, 5, 5.19, 5.5, 5.75, 6" (108, 114, 121, 127, 132, 140, 145, 152mm)
Electronic Counter	1-24 portions per stack
Maximum Stack Height	6" (152mm)

NovaMax500™ INNOVATIONS WILL IMPACT YOUR BOTTOM LINE

LOWER COST OF OWNERSHIP	EXCELLENT PRODUCT QUALITY
<ul style="list-style-type: none">- Minimal moving and stationary parts- All servo/electronic operation- Simplified servo mold plate drive- Servo controlled "next generation" rotary product pump- Utilizes existing F-19™ tooling, breather plates, fill plates, K.O. assemblies, mold plates and spacers- Dual feed screws- Gearmotor Feed Screw drive- One piece pump box extends mold plate life by reducing drive loads	<ul style="list-style-type: none">- Reduced air entrapment- Reduced leakage with entirely contained pump rotors- Identical F-19™ pump box configuration- Virtually no hopper leakage- Rotary pump improves product integrity with reduced shear and particle reduction- Servo controlled product fill pressure- Improved first cycle fill consistency
ADVANCED HYGIENE	SUPERIOR PRODUCTIVITY
<ul style="list-style-type: none">- One piece pump box- Uni-body frame construction- Removable feed screws- Tilting product hopper- All pump components can be COP tank cleaned	<ul style="list-style-type: none">- Up to 6,000 lbs (2722 kg) per hour- Up to 100 strokes per minute- Easy mechanical stroke length change

**FORMAX**
There's more in it for you.

Provisur® Technologies, Inc.

USA 9150 191st Street, Mokena IL 60448 (near Chicago) 708 479 3500 (fax 708 479 3598) E-mail: formaxinfo@provisur.com

The Netherlands Schipholweg 315, 1171 PL Badhoevedorp (near Amsterdam) (+31) 20-6590800 (fax +31) 20-6590801 E-mail: eu.info@provisur.com

South America Alameda Verus, 209, American Park Empresarial NR Indaianauba, SP 13347-859 Brazil Tel: +55 (19) 3305-3177 Fax: +55 (19) 3303-2148 Email: sa.info@provisur.com

Asia Pacific 11th Floor, Thaniya Building (315 Wing), 62 Sukon Road, Bangkok Bangkok 10500 Thailand Tel: +66 (0) 2652 3050 to 51 Fax: +66 (0) 2652 3052 Email: ap.info@provisur.com

©2011 Provisur® Technologies, Inc. FM1208