

VANMARK®

SERIES 4500

EVEN FEEDER CONVEYOR FOR WET APPLICATIONS



Other configurations available in the 4500 Series such as those shown above feature a rectangular tank with Vanmark's exclusive 5-sided corners and round outlet.

Model 4515 shown with 14 cu. ft. (0.4 m³) integral wet hopper and remote control variable speed drive

- * Designed to handle product in wet applications. Conveys whole or sliced product.
- * Elevates and evenly meters product from wet surge hopper into process line.
- * "No-cling" flight and final rinse spray bar assure wet and consistent product transfer.
- * Available in a wide range of flow rates and hopper sizes to transfer hundreds to thousands of pounds per hour of potatoes, fruits, vegetables or similar products.
- * Variable speed drive allows quick adjustment to process needs.
- * Unique hopper designs eliminate bridging so hopper empties completely.
- * Can be equipped with a variety of discharge chutes.
- * Conveyor cleanouts and non-lube lower pulley make unit easy to maintain. Rounded and sloped surfaces minimize accumulation of debris and reduce cleaning time.
- * Stainless steel welded construction throughout for long life and better sanitation.



VANMARK® CORPORATION

INDUSTRIAL PARKWAY □ CRESTON IOWA 50801
TEL 641-782-6575 □ 800-523-6261
FAX 641-782-9209 □ www.vanmarkcorp.com

...equipment for the food industry...

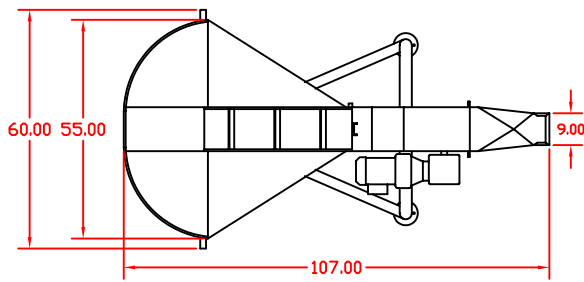

SPECIFICATIONS	
MOTOR	230/460 V, 60 Hz, 3 ph, ¾ hp
CONTROL	115 V, 1 ph., 3 amps
DIMENSIONS	varies by model
WEIGHT (approximate)	1200 lbs (545 kg)

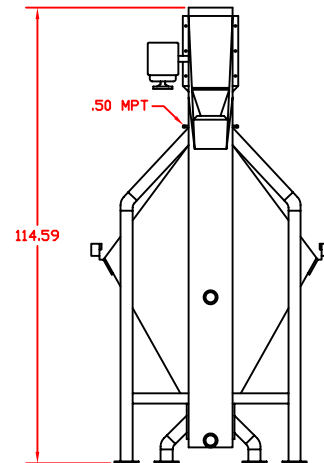
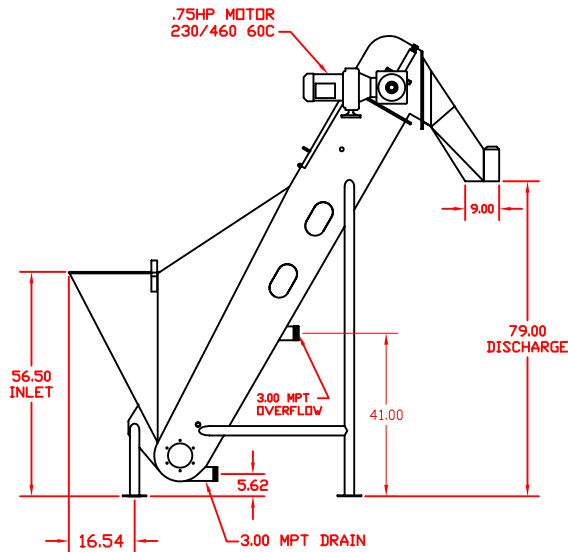

Spray bar gives product final rinse and provides tank makeup water.

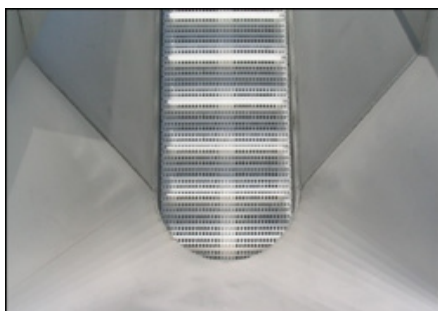

Design assures hopper will empty completely and is easy to clean. Belt feeds product evenly.

The Vanmark Series 4500 Even Feeder provides consistent, uniform metering of wet product into downstream processes. It is specifically designed for wet applications such as feeding peeled product to slicers.

The low profile and spacing of belt flights are engineered to create a single layer of product across the full width of the conveyor. This results in a steady flow of product from the hopper, without the usual “dribble to deluge” common with other feed conveyors.

The series is available with several sizes of tanks including those shown in the inset opposite. Rectangular tanks feature Vanmark’s exclusive 5-sided corners and round outlet to eliminate product bridging. Hoppers empty completely.

A variety of chutes can be fitted to the Series 4500, including a remotely controlled product diverter to direct product to two separate lines.

For more information or a quote, contact your regional Vanmark representative, visit our website, or call 800-523-6261.

